

RoHS
COMPLIANT

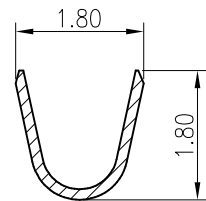

SECTION A-A

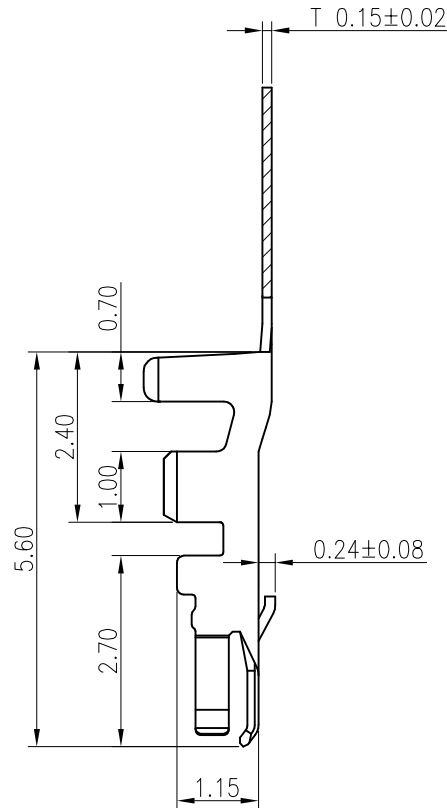
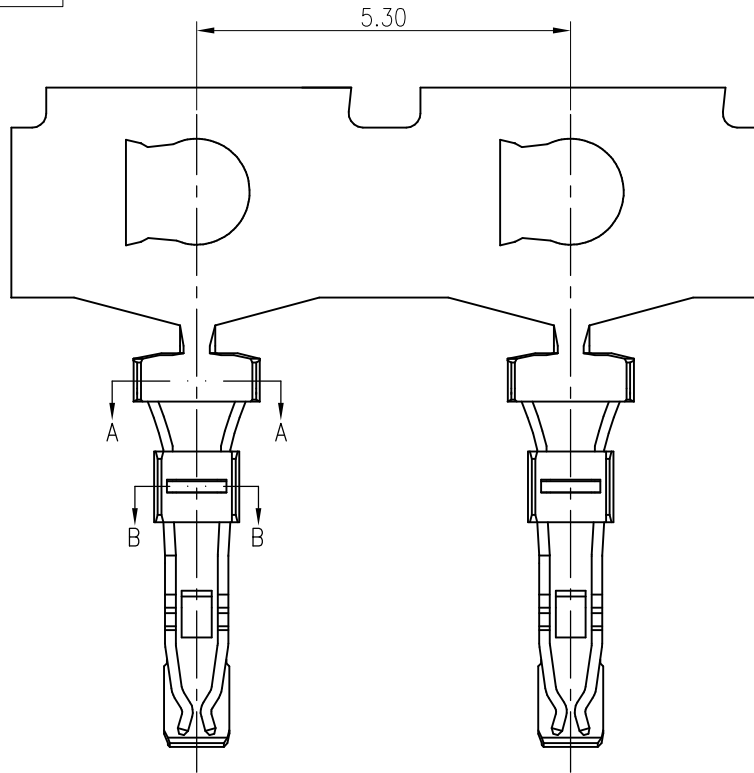
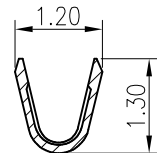

SECTION B-B

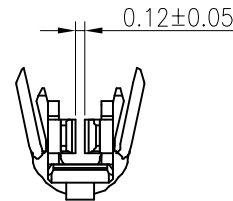

SPECIFICATIONS

1. Current rating: 3A AC, DC
2. Voltage rating: 150V AC,DC
3. Temperature range: -25°C ~ +85°C
4. Insulation resistance: 1000MΩ/ min.
5. Withstanding voltage: 500V AC/ minute.
6. Contact resistance: 20mΩ/ max.

Applicable Wires:

AWG#24~#28

Insulation O.D. : 1.10mm MAX

Material: Phosphor Bronze

Plating: Gold flash over Nickel

Suitable 1509 series crimp housing

Q'ty/reel: 10,000 PCS

F	△4				TOLERANCE X.X ±0.30 X.XX ±0.20 X.XXX ±0.10 Angle ±2°	TITLE: 1.5 Side Buckel Terminal	DRAWN: Arvin 2020.03.05		KONNRA 东莞市康瑞电子有限公司		
	△3						CHECKED:		DongGuan Konnra Electronics Co., Ltd.		
	△2						APPROVED:		PART NO. : T15090PG0101A		
	MARK	REVISION DESCRIPTION	SIGNATURE	DATE			UNIT: mm	SCALE: N/A	SHEET: 1/1	PROJECTION	REV. : A1
	1	2	3	4	5	6	7	8	9		