

RoHS
COMPLIANT

Step 1: Place Housing into PE bag and seal PE bag. Label.
将 Housing放入PE袋内, 并将PE袋封好, 贴上标签.

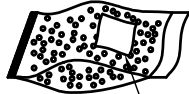
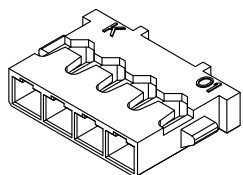

Label

Step 2: Put PE bag packed products in cartons,
Packing detail see the table right
将装好产品的PE袋放入纸箱内, 详细包装见右表

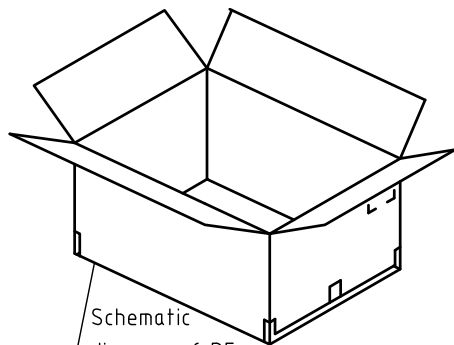

Schematic diagram of PE bag placement

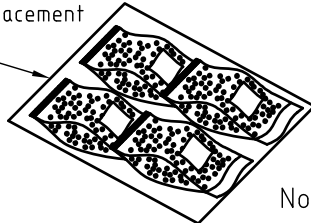

Step 3: Put PE bag packed products in cartons,
Packing detail see the table right
将装好产品的PE袋放入纸箱内, 详细包装见右表

Adhesive Tape

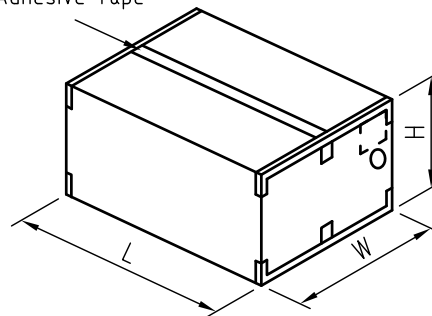

Circuits	PCS/Bag
2	2000
3	2000
4	2000
5	2000
6	2000
7	2000
8	2000

Note注解:

- There shall be no dirt such as deformation phenomenon, Mantissa box fillers must be used
每箱不可有脏污, 变形现象, 尾数箱必须用填充物
- Confirm whether the inner and outer labels are missing and the content must be consistent with the actual product
确认内外标签有无漏失, 内容与实物必须一致
- Packing quantity per carton depends on order and delivery quantity
每箱包装数量依订单及交货数量而定

	SPEC.	Remark
Carton 1	L460mm×W460mm×H510mm	Use the appropriate carton size according to the actual order quantity 根据实际订单数量使用合适的纸箱尺寸
Carton 2	L500mm×W500mm×H305mm	
Carton 3	L580mm×W580mm×H320mm	



MARK

TOLERANCE
X.X ±0.30
X.XX ±0.20
X.XXX ±0.10
Angle ±2°

TITLE:
ACH1.2 Housing
Packing

DRAWN: Arwin 2020.03.05

CHECKED:

APPROVED:

UNIT:mm SCALE:N/A

SHEET:1/1

PROJECTION

KONNRA 东莞市康瑞电子有限公司
DongGuan Konnra Electronics Co.,Ltd.

PART NO.:H12010*****01A

REV.:A1 DRAWING NO.:1201H01-A-P

RoHS
COMPLIANT

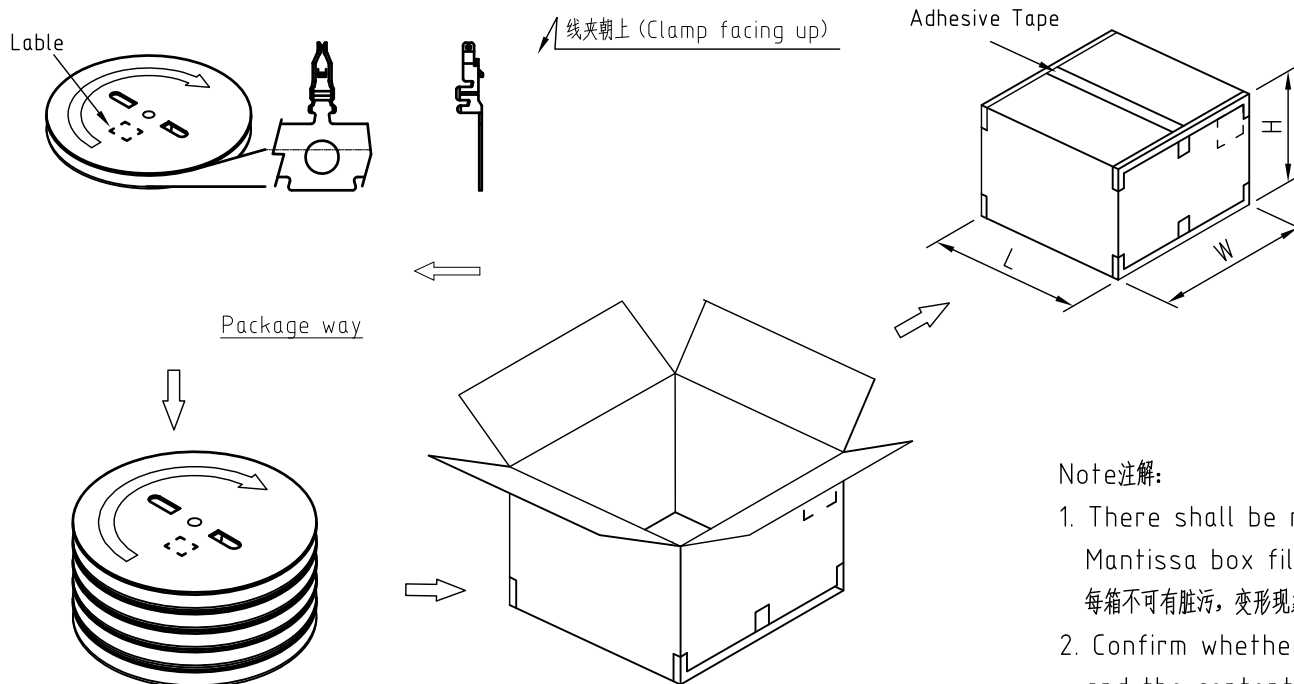

Note注解:

- There shall be no dirt such as deformation phenomenon, Mantissa box fillers must be used
每箱不可有脏污，变形现象，尾数箱必须用填充物
- Confirm whether the inner and outer labels are missing and the content must be consistent with the actual product
确认内外标签有无漏失，内容与实物必须一致
- Quantity(数量): 25K PCS/REEL (25K PCS/盘)
Packing quantity per carton depends on order and delivery quantity
每箱包装数量依订单及交货数量而定

	SPEC.	Remark
Carton 1	L460mm×W460mm×H510mm	Use the appropriate carton size according to the actual order quantity 根据实际订单数量使用合适的纸箱尺寸
Carton 2	L500mm×W500mm×H305mm	
Carton 3	L580mm×W580mm×H320mm	

F					TOLERANCE	TITLE:	DRAWN: <i>Arwin 2020.03.05</i>	KONNRA 东莞市康瑞电子有限公司 DongGuan Konnra Electronics Co.,Ltd.				
					X.X ±0.30	MX1.2 Terminal	CHECKED:					
					X.XX ±0.20	Package	APPROVED:	PART NO.: T12000P***01A				
MARK	REVISION DESCRIPTION	SIGNATURE	DATE	X.XXX ±0.10	Angle ±2°	UNIT:mm	SCALE:N/A	SHEET: 1/1	PROJECTION	REV.: A1	DRAWING NO.: 1200T101-A-P	

RoHS
COMPLIANT

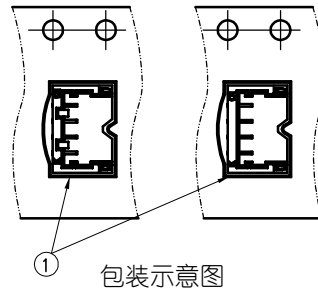
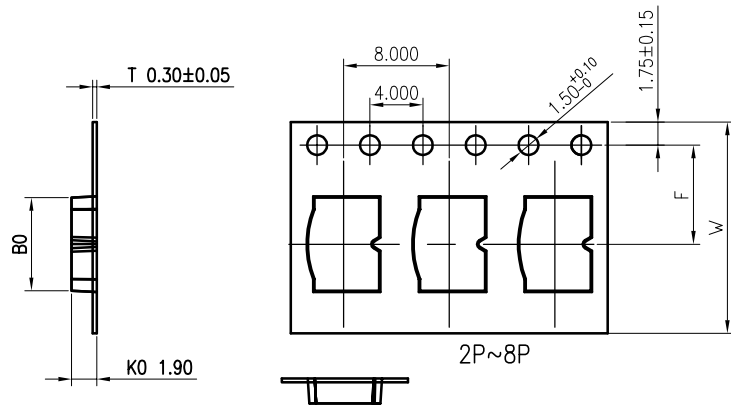

- NOTES:
 1. All dimensions meet EIA-481-D requirements.
 2. Material: White PS
 3. Carrier cam not to exceed 1mm in 250mm.
 4. A.Length:48.68m (507 模)
 5.Reel:15" 胶盘

封装时收料方向

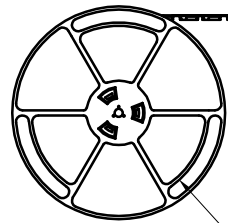

REEL



放干燥剂, 真空包装

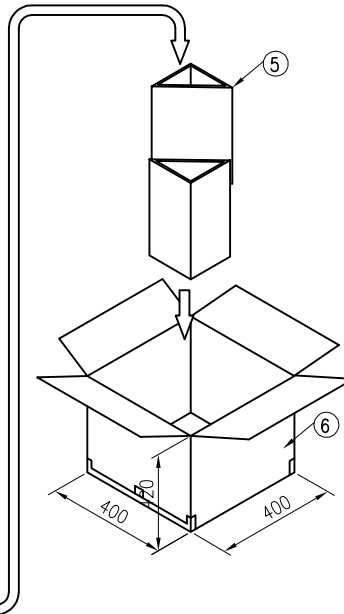
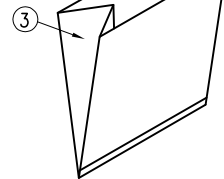
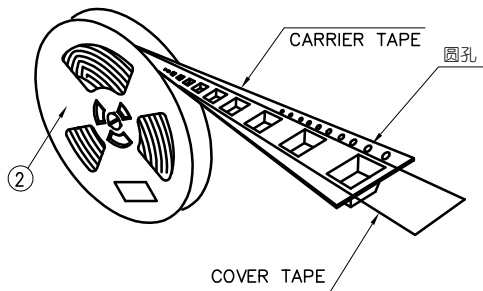

CTK.	DIMENSIONS			Q'ty/BOX
	W±0.3	F±0.15	B0	
2P	12.0	5.50	4.60	24R*6000
3P	16.0	7.50	5.60	19R*6000
4P	16.0	7.50	7.05	19R*6000
5P	16.0	7.50	8.20	19R*6000
6P	24.0	11.50	9.40	14R*6000
7P	24.0	11.50	10.60	14R*6000
8P	24.0	11.50	11.80	14R*6000

NO.	NAME	SPEC.	Q'TY
①	PRODUCT	MX1/JST1.2 SMT 90°WF系列	6000 PCS/R
②	卷盘/载带	--	1SET
③	透明真空袋	550×500×0.10mm	1PCS/Reel
④	干燥剂	--	1PCS/Reel
⑤	三角纸板	410×90×90mm	适量
⑥	纸箱	400×400×420mm	适量
⑦	标签	--	适量

△4				TOLERANCE	TITLE:	DRAWN: Arvin 2020.03.05	KONNRA 东莞市康瑞电子有限公司 DongGuan Konnra Electronics Co., Ltd.
△3				X. X ±0.30	MK/JST1.2 SMT 90°	CHECKED:	
△2	更改料号及图框格式	Arvin	2020.03.05	X. XX ±0.20	WF系列卷带包装图	APPROVED:	
MARK	REVISION DESCRIPTION	SIGNATURE	DATE	X. XXX ±0.10	UNIT: mm	SHEET: 1/1	
				Angle ±2°	SCALE: N/A	PROJECTION	REV.: A2
1	2	3	4	5	6	7	DRAWING NO.: 1200WHS101-A-P