

RoHS
COMPLIANT

Step 1: Place Housing into PE bag and seal PE bag. Label.
将 Housing放入PE袋内, 并将PE袋封好, 贴上标签.

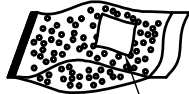
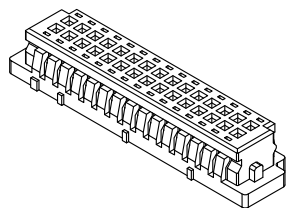

Label

Step 2: Put PE bag packed products in cartons,
Packing detail see the table right
将装好产品的PE袋放入纸箱内, 详细包装见右表

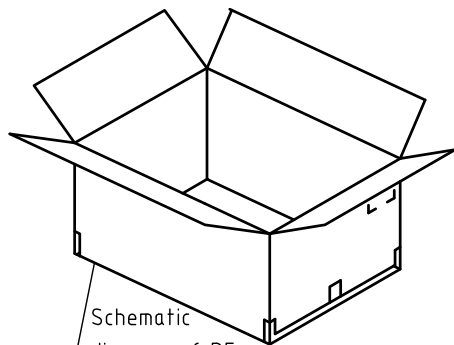

Schematic diagram of PE bag placement

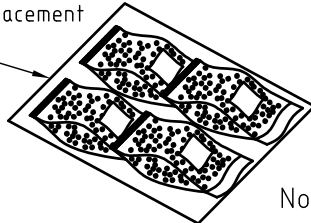

Step 3: Put PE bag packed products in cartons,
Packing detail see the table right
将装好产品的PE袋放入纸箱内, 详细包装见右表

Adhesive Tape

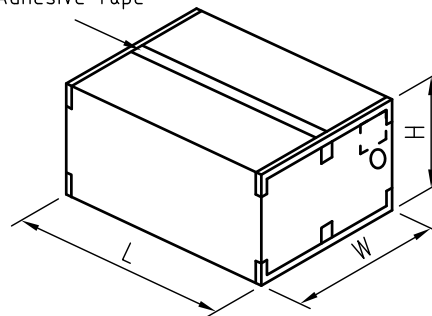

Circuits	PCS/Bag
2×5	1000
2×7	1000
2×10	1000
2×15	1000
2×20	1000

Note注解:

1. There shall be no dirt such as deformation phenomenon, Mantissa box fillers must be used
每箱不可有脏污, 变形现象, 尾数箱必须用填充物
2. Confirm whether the inner and outer labels are missing and the content must be consistent with the actual product
确认内外标签有无漏失, 内容与实物必须一致
3. Packing quantity per carton depends on order and delivery quantity
每箱包装数量依订单及交货数量而定

	SPEC.	Remark
Carton 1	L460mm×W460mm×H510mm	Use the appropriate carton size according to the actual order quantity 根据实际订单数量使用合适的纸箱尺寸
Carton 2	L500mm×W500mm×H305mm	
Carton 3	L580mm×W580mm×H320mm	



MARK

1

2

3

4

5

6

7

8

9

TOLERANCE

X.X ±0.30

X.XX ±0.20

X.XXX ±0.10

Angle ±2°

TITLE:
DF13 Two rows
HOUSING Packing

UNIT:mm

SCALE:N/A

DRAWN: Arwin 2020.03.05

CHECKED:

APPROVED:

SHEET:1/1

PROJECTION

KONNRA 东莞市康瑞电子有限公司
DongGuan Konnra Electronics Co.,Ltd.

PART NO.:H12560*****01B

REV.:A1 DRAWING NO.:1256H201-B-P

RoHS
COMPLIANT

Step 1: Place Housing into PE bag and seal PE bag. Label.
将 Housing放入PE袋内, 并将PE袋封好, 贴上标签.

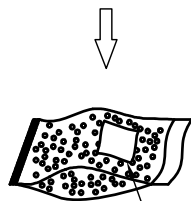
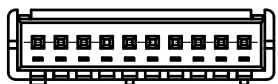

Step 2: Put PE bag packed products in cartons,
Packing detail see the table right
将装好产品的PE袋放入纸箱内, 详细包装见右表

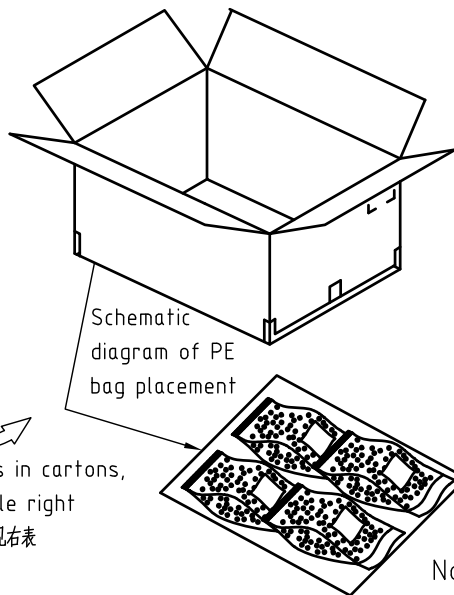

Step 3: Put PE bag packed products in cartons,
Packing detail see the table right
将装好产品的PE袋放入纸箱内, 详细包装见右表

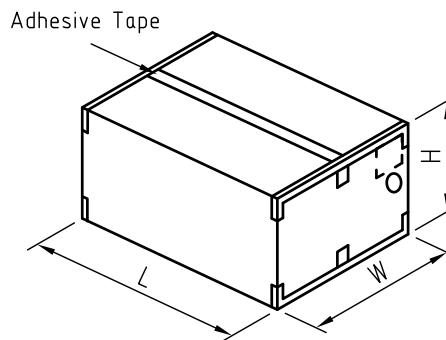

Circuits	PCS/Bag
2	1000
3	1000
4	1000
5	1000
6	1000
7	1000
8	1000
9	1000
10	1000
11	1000
12	1000
13	1000
14	1000
15	1000

Note注解:

- There shall be no dirt such as deformation phenomenon, Mantissa box fillers must be used
每箱不可有脏污, 变形现象, 尾数箱必须用填充物
- Confirm whether the inner and outer labels are missing and the content must be consistent with the actual product
确认内外标签有无漏失, 内容与实物必须一致
- Packing quantity per carton depends on order and delivery quantity
每箱包装数量依订单及交货数量而定

	SPEC.	Remark
Carton 1	L460mm×W460mm×H510mm	Use the appropriate carton size according to the actual order quantity 根据实际订单数量使用合适的纸箱尺寸
Carton 2	L500mm×W500mm×H305mm	
Carton 3	L580mm×W580mm×H320mm	



MARK

TOLERANCE
X.X ±0.30
X.XX ±0.20
X.XXX ±0.10
Angle ±2°

TITLE:
DF13 HOUSING
Packing

DRAWN: Arwin 2020.03.05

CHECKED:

APPROVED:

UNIT:mm SCALE:N/A

SHEET:1/1

PROJECTION

KONNRA 东莞市康瑞电子有限公司
DongGuan Konnra Electronics Co.,Ltd.

PART NO.:H12560*****01D

REV.:A1 DRAWING NO.:1256H01-D-P

RoHS
COMPLIANT

Step 1: Place Housing into PE bag and seal PE bag. Label.
将 Housing放入PE袋内, 并将PE袋封好, 贴上标签.

Step 3: Put PE bag packed products in cartons,
Packing detail see the table right
将装好产品的PE袋放入纸箱内, 详细包装见右表

DF13 DIP 90° / DF13 DIP 180°

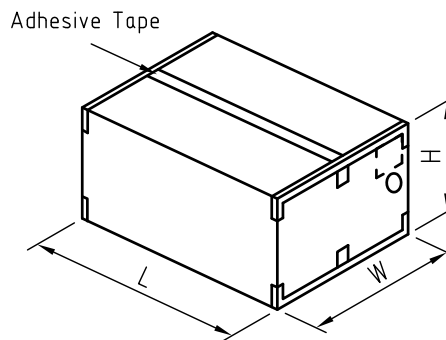
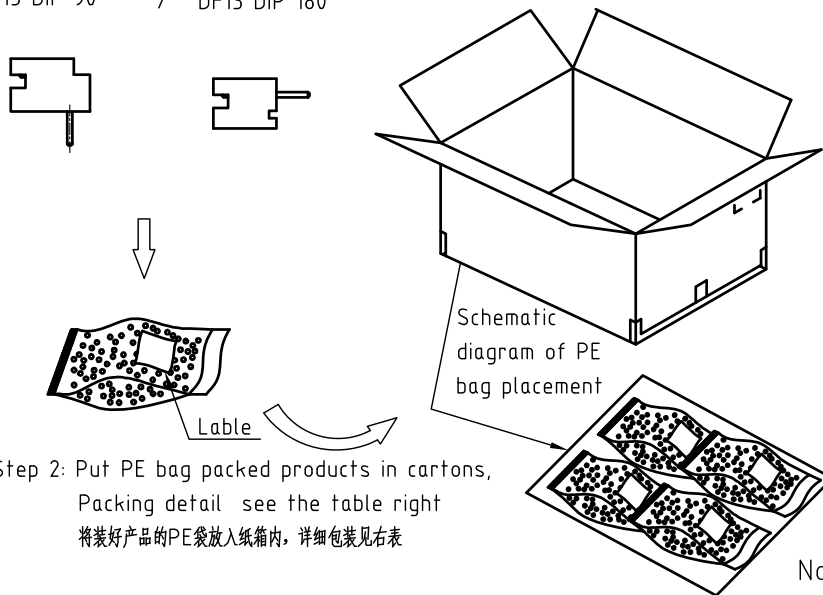

Step 2: Put PE bag packed products in cartons,
Packing detail see the table right
将装好产品的PE袋放入纸箱内, 详细包装见右表

Circuits	PCS/Bag
2	1000
3	1000
4	1000
5	1000
6	1000
7	1000
8	1000
9	1000
10	1000
11	1000
12	1000
13	1000
14	1000
15	1000
16	1000

Note注解:

1. There shall be no dirt such as deformation phenomenon, Mantissa box fillers must be used
每箱不可有脏污, 变形现象, 尾数箱必须用填充物
2. Confirm whether the inner and outer labels are missing and the content must be consistent with the actual product
确认内外标签有无漏失, 内容与实物必须一致
3. Packing quantity per carton depends on order and delivery quantity
每箱包装数量依订单及交货数量而定

	SPEC.	Remark
Carton 1	L460mm×W460mm×H510mm	Use the appropriate carton size according to the actual order quantity 根据实际订单数量使用合适的纸箱尺寸
Carton 2	L500mm×W500mm×H305mm	
Carton 3	L580mm×W580mm×H320mm	



MARK

TOLERANCE
X.X ±0.30
X.XX ±0.20
X.XXX ±0.10
Angle ±2°

TITLE:
DF13 DIP WF
Series Packing

DRAWN: *Arwin 2020.03.05*

CHECKED:

APPROVED:

UNIT:mm SCALE:N/A

SHEET:1/1

PROJECTION

KONNRA 东莞市康瑞电子有限公司
DongGuan Konnra Electronics Co.,Ltd.

PART NO.:C1256ND*****0101PA

REV.:A1 DRAWING NO.:1256WND101-A-P

1 2 3 4 5 6 7 8 9

RoHS
COMPLIANT

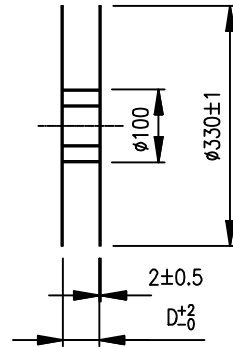
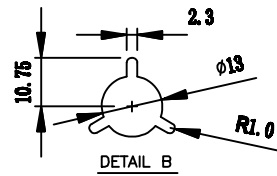
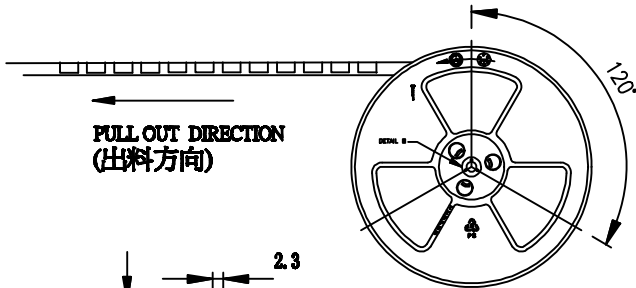
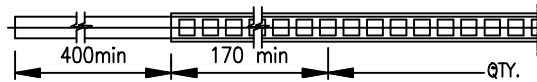

CKT.	A	B	C	D
10	11.15	12.40	24.00	24.40
14		14.90		
16		16.15		
20		18.65		
30	20.2±0.15	24.90	44.00	44.40
40		31.15		
50	26.2±0.1	37.40		

1. NOTE:

- MATERIAL:
P.S , COLOR : BLUE
THICKNESS: B=1.85±0.10 mm
ANTI-STATIC $10^9 \Omega/\square$
- FIRMLY ATTACHED DISC TO CORE, METHOD OPTIONAL.
- 轴心的厚度1.80MM

W>20

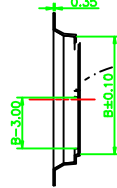
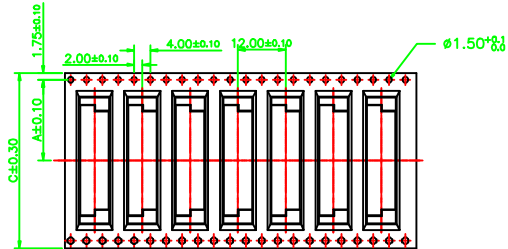

W<16

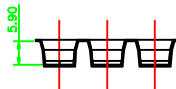
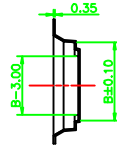
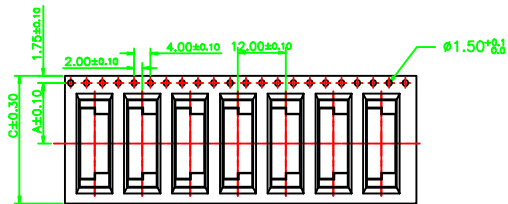

- Thickness : 0.35±0.05mm.
- Component load per 13" reel : 1000 pcs.



MARK

1

2

3

4

5

6

7

8

9

TOLERANCE

X.X ±0.30

X.XX ±0.20

X.XXX ±0.10

Angle ±2°

TITLE:

DF13 SMT Dual Row

Series packing

UNIT: mm

SCALE: N/A

DRAWN: Arvin 2020.03.05

CHECKED:

APPROVED:

SHEET: 1/1

PROJECTION

KONNRA 东莞市康瑞电子有限公司

DongGuan Konnra Electronics Co., Ltd.

PART NO.: C1256VS****0101RB

REV.: A1

DRAWING NO.: 1256WVS201-A-P

02~08 Contacts

09~15 Contacts

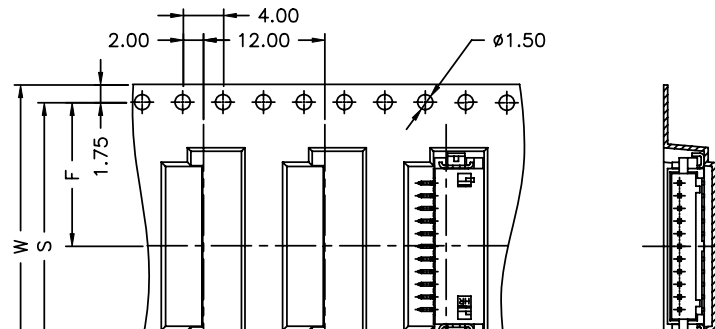
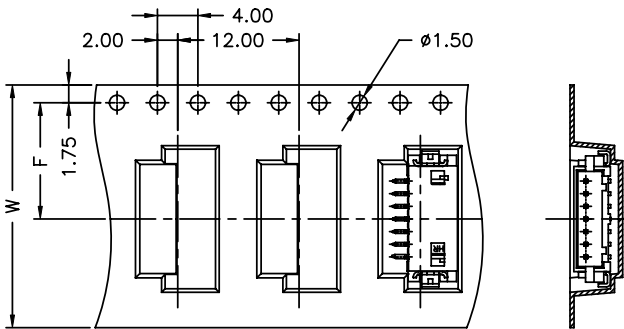

Unreeling direction →

Unreeling direction →

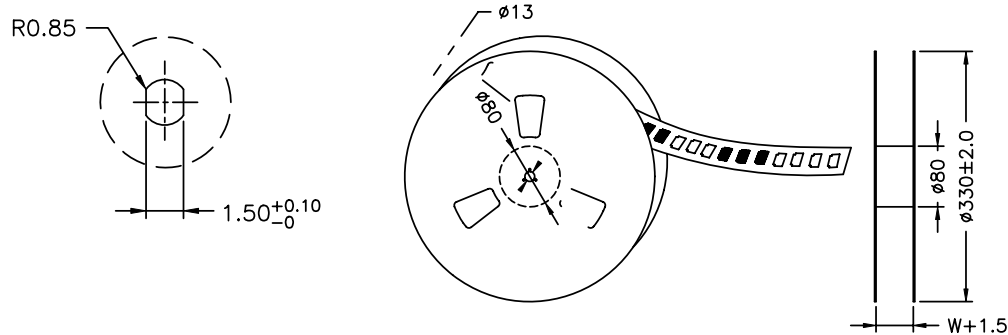
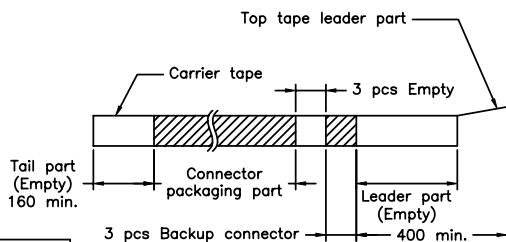

NOTE:
Material: Transparent
Anti-static Polystyrene.

Number of Contacts	W±0.3	F±0.1	S±0.1	Q'ty/Reel
02P	16	7.50	/	1,000
03P	16	7.50		1,000
04P	24	11.50		1,000
05P	24	11.50		1,000
06P	24	11.50		1,000
07P	24	11.50		1,000
08P				1,000
09P	32	14.20		28.40
10P	32	14.20	28.40	1,000
11P	32	14.20	28.40	1,000
12P	32	14.20	28.40	1,000
13P	32	14.20	28.40	1,000
14P	44	20.20	40.40	1,000
15P	44	20.20	40.40	1,000

				TOLERANCE	TITLE:	DRAWN: Shen 2020.6.18	KONNRA 东莞市康瑞电子有限公司	
				X.X ±0.30	DF13 SMT 90°Wafer	CHECKED:	DongGuan Konnra Electronics Co.,Ltd.	
				X.XX ±0.20	Series packing	APPROVED:	PART NO.: C1256RS****G0101RA	
				X.XXX ±0.10			REV.: A1 DRAWING NO. 1256WRS101-A-P	
				Angle ±2°	UNIT:mm	SCALE: 1/1	SHEET: 1/1	PROJECTION
MARK	REVISION DESCRIPTION	SIGNATURE	DATE					

RoHS
COMPLIANT

02~08 Contacts

09~15 Contacts

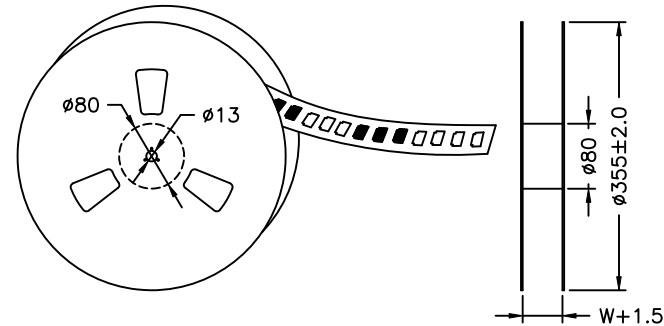
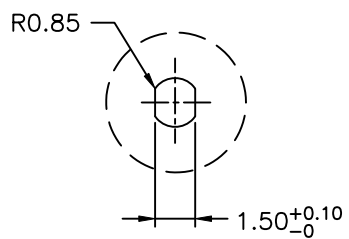
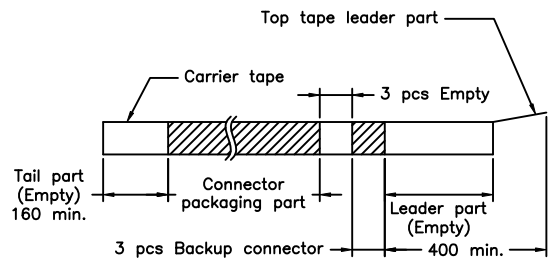
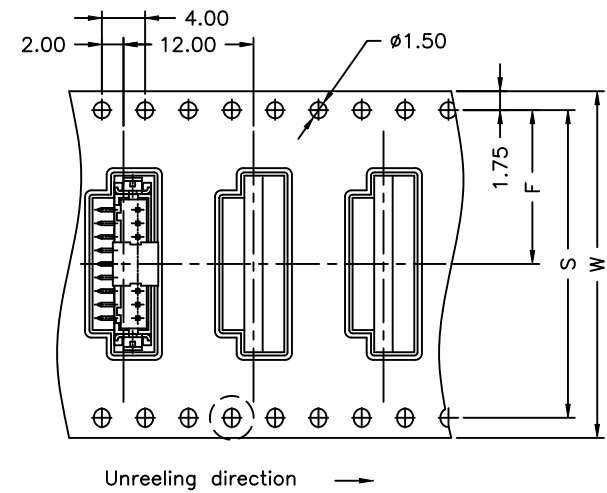
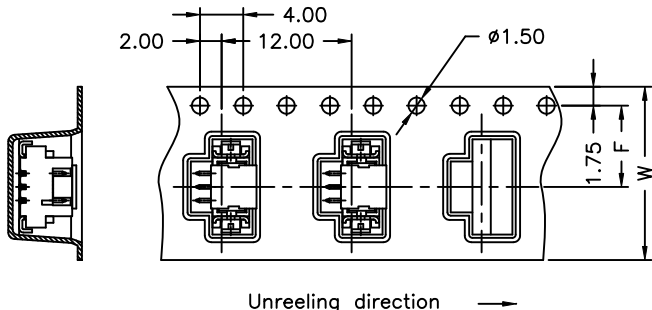

Number of Contacts	W±0.3	F±0.1	S±0.1	Q'ty/Reel
02P	16	7.50		1,000
03P	16	7.50		1,000
04P	24	11.50		1,000
05P	24	11.50		1,000
06P	24	11.50		1,000
07P	24	11.50		1,000
08P	24	11.50		1,000
09P	32	14.20		28.40
10P	32	14.20	28.40	1,000
11P	32	14.20	28.40	1,000
12P	32	14.20	28.40	1,000
13P	44	20.20	40.40	1,000
14P	44	20.20	40.40	1,000
15P	44	20.20	40.40	1,000

NOTE:
Material:Transparent
Anti-static Polystyrene.

F	TOLERANCE		TITLE:		DRAWN: Shen 2020.6.18		KONNRA 东莞市康瑞电子有限公司				
	X.X ±0.30		DF13 SMT 180°Wafer		CHECKED:		DongGuan Konnra Electronics Co.,Ltd.				
F	X.XX ±0.20		Series packing		APPROVED:		PART NO.: C1256VS****G0101RA				
	X.XXX ±0.10		UNIT:mm		SCALE:1/1		SHEET:1/1		PROJECTION		
MARK		REVISION DESCRIPTION		SIGNATURE		DATE		REV.:A1		DRAWING NO. 1256WVS101-A-P	