

RoHS
COMPLIANT

Step 1: Place Housing into PE bag and seal PE bag. Label.
将 Housing放入PE袋内, 并将PE袋封好, 贴上标签.

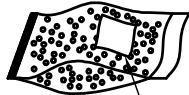
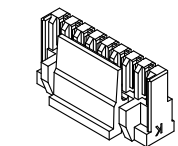

Label

Step 2: Put PE bag packed products in cartons,
Packing detail see the table right
将装好产品的PE袋放入纸箱内, 详细包装见右表

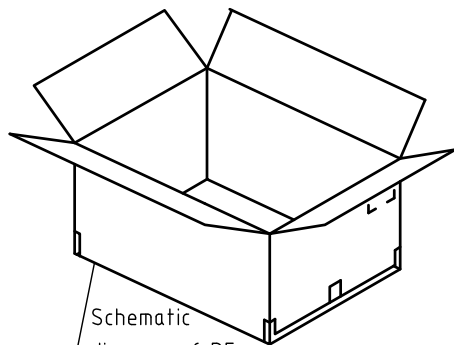

Schematic diagram of PE bag placement

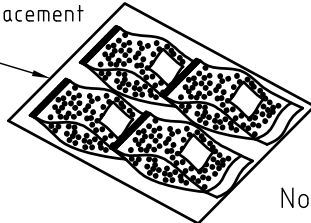

Step 3: Put PE bag packed products in cartons,
Packing detail see the table right
将装好产品的PE袋放入纸箱内, 详细包装见右表

Adhesive Tape

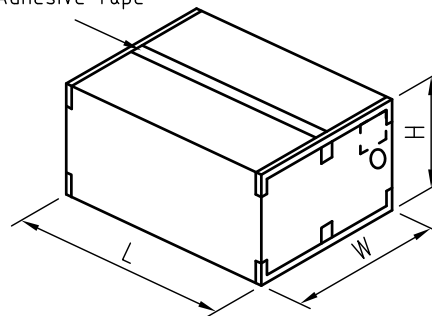

Circuits	PCS/Bag
2	1000
3	1000
4	1000
5	1000
6	1000
7	1000
8	1000
9	1000
10	1000
11	1000
12	1000

Note注解:

1. There shall be no dirt such as deformation phenomenon, Mantissa box fillers must be used
每箱不可有脏污, 变形现象, 尾数箱必须用填充物
2. Confirm whether the inner and outer labels are missing and the content must be consistent with the actual product
确认内外标签有无漏失, 内容与实物必须一致
3. Packing quantity per carton depends on order and delivery quantity
每箱包装数量依订单及交货数量而定

	SPEC.	Remark
Carton 1	L460mm×W460mm×H510mm	Use the appropriate carton size according to the actual order quantity 根据实际订单数量使用合适的纸箱尺寸
Carton 2	L500mm×W500mm×H305mm	
Carton 3	L580mm×W580mm×H320mm	



MARK

1

2

3

4

5

6

7

8

9

TOLERANCE

X.X ±0.30
X.XX ±0.20
X.XXX ±0.10
Angle ±2°

TITLE:
GH1.25 Housing
Package
specification

UNIT:mm SCALE:N/A

DRAWN: Arwin 2020.03.05

CHECKED:

APPROVED:

SHEET:1/1 PROJECTION

KONNRA 东莞市康瑞电子有限公司
DongGuan Konnra Electronics Co.,Ltd.

PART NO.:H12590****01A

REV.:A1 DRAWING NO.:1259H01-A-P

RoHS
COMPLIANT

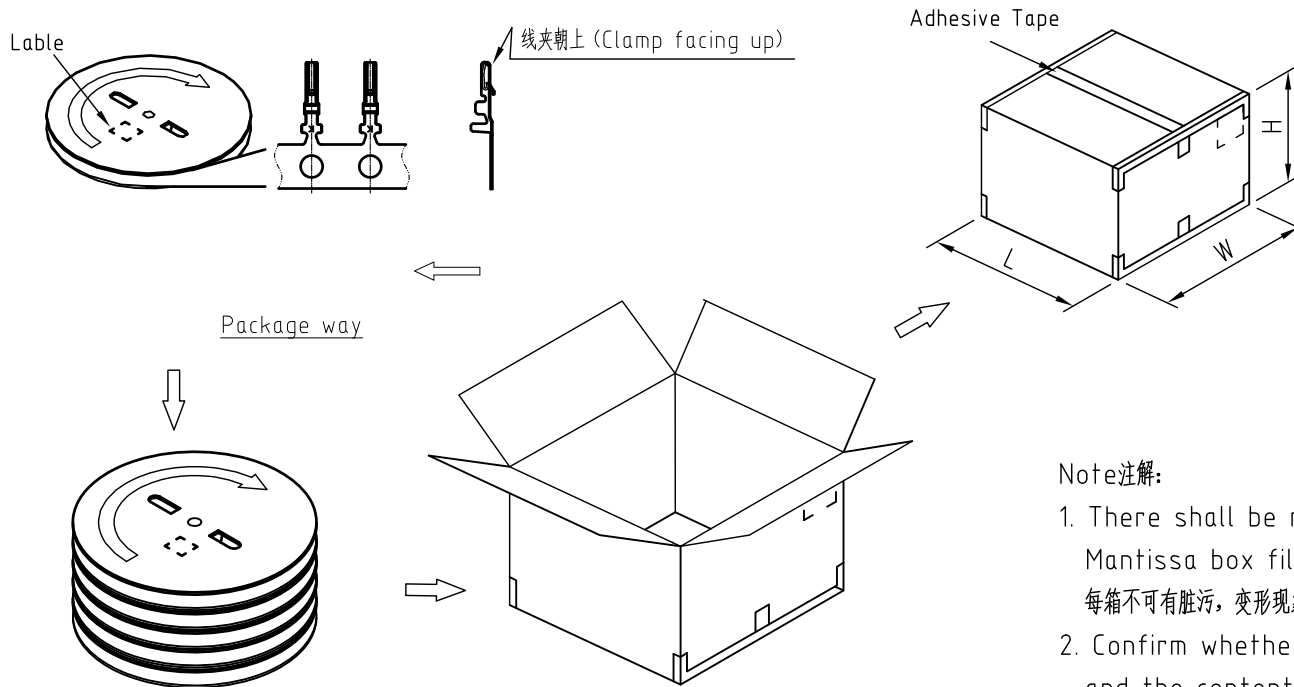

Note注解:

1. There shall be no dirt such as deformation phenomenon, Mantissa box fillers must be used
每箱不可有脏污，变形现象，尾数箱必须用填充物
2. Confirm whether the inner and outer labels are missing and the content must be consistent with the actual product
确认内外标签有无漏失，内容与实物必须一致
3. Quantity(数量): 20K PCS/REEL (20K PCS/盘)
Packing quantity per carton depends on order and delivery quantity
每箱包装数量依订单及交货数量而定

	SPEC.	Remark
Carton 1	L460mm×W460mm×H510mm	Use the appropriate carton size according to the actual order quantity 根据实际订单数量使用合适的纸箱尺寸
Carton 2	L500mm×W500mm×H305mm	
Carton 3	L580mm×W580mm×H320mm	

F					TOLERANCE	TITLE:	DRAWN: <i>Arwin 2020.03.05</i>	KONNRA 东莞市康瑞电子有限公司 DongGuan Konnra Electronics Co.,Ltd.			
					X.X ±0.30	GH1.25 Terminal Package Specification	CHECKED:				
					X.XX ±0.20		APPROVED:	PART NO.: T12590P***01A			
MARK	REVISION DESCRIPTION	SIGNATURE	DATE	X.XXX ±0.10	Angle ±2°	UNIT:mm	SCALE:N/A	SHEET: 1/1	PROJECTION	REV.: A1	DRAWING NO.: 1259T01-A-P

1 2 3 4 5 6 7 8 9

RoHS
COMPLIANT

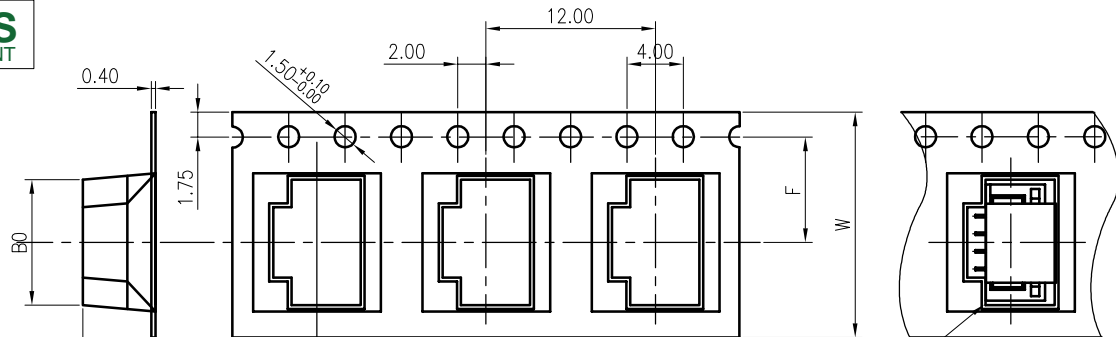

① 包装示意图

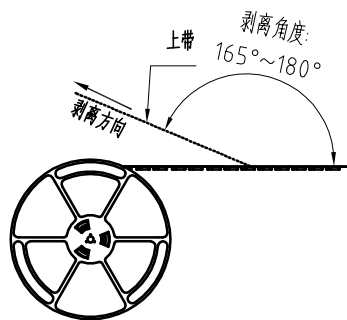
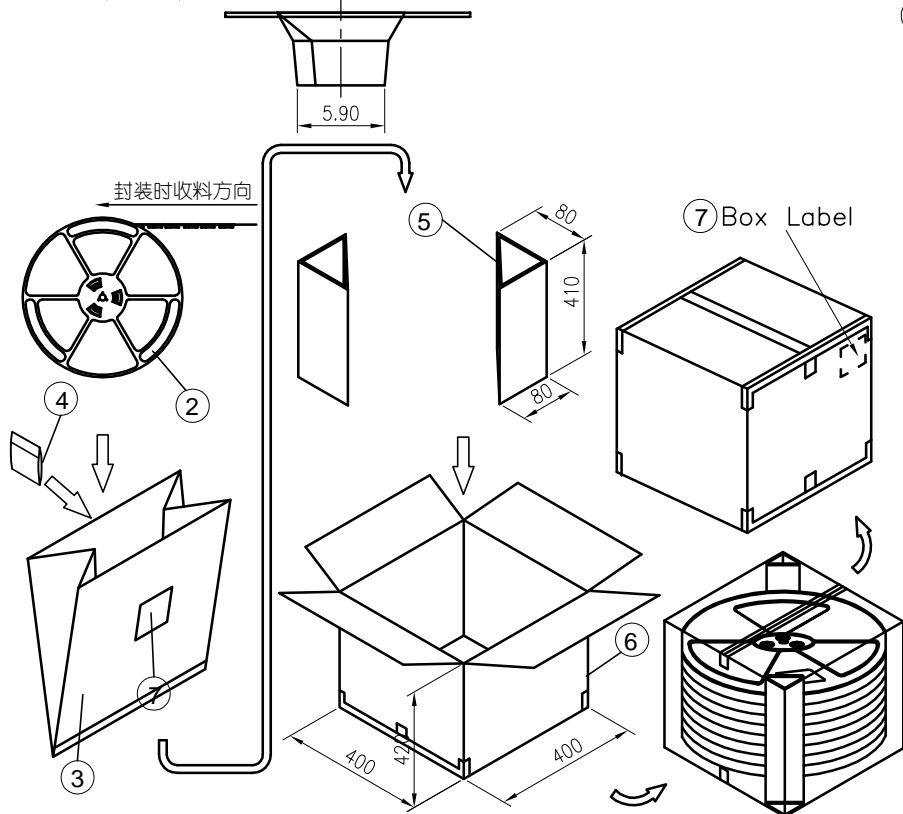

包装方式:

- 产品按要放入载带卷盘(参考《产品卷带包装对照表》),需测试上带剥离力(剥离角度: 165~180°; 剥离速度: 300±10mm/min):
1.1 W=12~56,剥离力0.1N~1.3N;
1.2 W=72以上,剥离力0.1N~1.5N;
- 产品卷盘包装后,进行抽真空作业(每袋内装入1PCS干燥剂,依要求贴上标签;
- 将三角纸板放入纸箱固定,再将真空包装好的产品放入纸箱内,之后用胶带封箱,并在外箱相应位置贴上标签(若卷盘数量不够整箱,纸箱和三角板高度依实际包装适量修剪或填充.

CTK.	DIMENSIONS			Q'ty/BOX (PCS)
	W	F	B0	
2P	16.0	7.50	6.00	19*1500
3P	16.0	7.50	7.25	19*1500
4P	16.0	7.50	8.50	19*1500
5P	24.0	11.50	9.75	14*1500
6P	24.0	11.50	11.00	14*1500
7P	24.0	11.50	12.25	14*1500
8P	24.0	11.50	13.50	14*1500
9P	24.0	11.50	14.85	14*1500
10P	32.0	14.20	16.10	11*1500
11P	32.0	14.20	17.35	11*1500
12P	32.0	14.20	18.60	11*1500
13P	32.0	14.20	19.85	11*1500
14P	44.0	20.20	21.10	8*1500

NO.	NAME	SPEC.	Q'TY
①	PRODUCT	GH1.25 SMT 180°WF系列	参照上表(特殊除外)
②	卷盘/载带	--	1SET
③	透明真空袋	550×500×0.10mm	1PCS/Reel
④	干燥剂	--	1PCS/Reel
⑤	三角纸板	410×80×80mm	4PCS
⑥	纸箱	400×400×420mm	1PCS
⑦	标签	--	2PCS



MARK

1

2

3

4

5

6

7

8

9

TOLERANCE

X.X ±0.30
X.XX ±0.20
X.XXX ±0.10
Angle ±2°

TITLE:

GH1.25 SMT 180° WF
卷装包装规范

UNIT: mm

SCALE: N/A

DRAWN: Arvin 2020.03.05

CHECKED:

APPROVED:

SHEET: 1/1

PROJECTION

KONNRA 东莞市康瑞电子有限公司
DongGuan Konnra Electronics Co., Ltd.

PART NO.: C1259VS1**09*010*RA

REV.: A1 DRAWING NO.: 1259WS101-A-P

RoHS
COMPLIANT

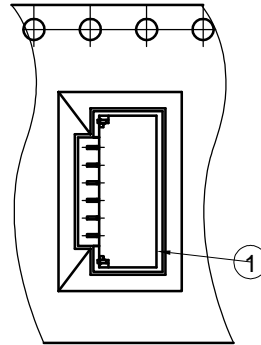
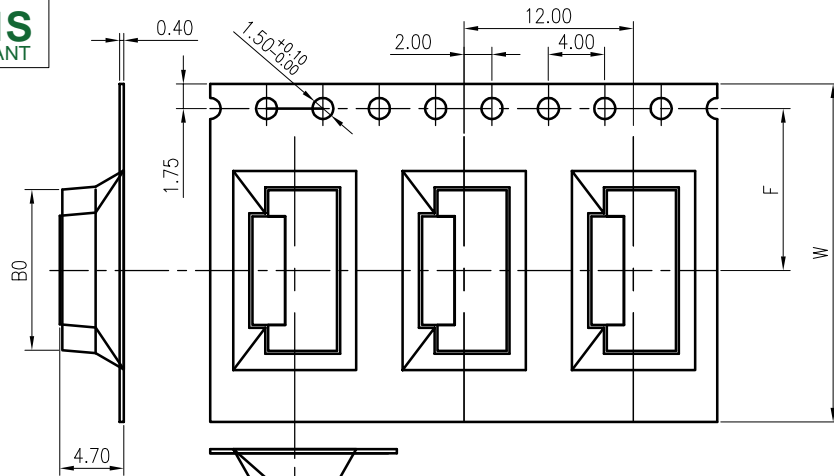

包装示意图 上带 剥离角度: 165°~180°

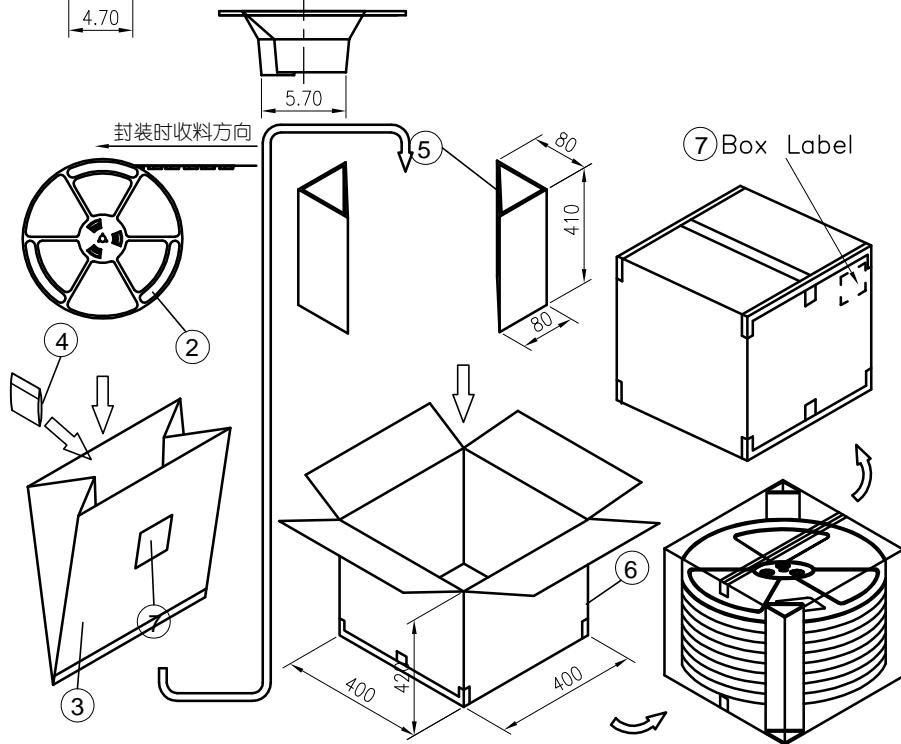
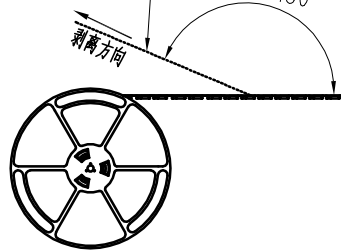

包装方式:

- 产品按要求放入载带卷盘(参考《产品卷带包装对照表》),需测试上带剥离力(剥离角度: 165~180°; 剥离速度: 300±10mm/min);
1.1 W=12~56,剥离力0.1N~1.3N;
1.2 W=72以上,剥离力0.1N~1.5N;
- 产品卷盘包装后,进行抽真空作业(每袋内装入1PCS干燥剂),依要求贴上标签;
- 将三角纸板放入纸箱固定,再将真空包装好的产品放入纸箱内,之后用胶带封箱,并在外箱相应位置贴上标签(若卷盘数量不够整箱,纸箱和三角板高度依实际包装适量修剪或填充).

CTK.	DIMENSIONS			Q'ty/BOX (PCS)
	W	F	B0	
2P	16.0	7.50	6.00	19*1500
3P	16.0	7.50	7.25	19*1500
4P	16.0	7.50	8.50	19*1500
5P	24.0	11.50	9.75	14*1500
6P	24.0	11.50	11.00	14*1500
7P	24.0	11.50	12.25	14*1500
8P	24.0	11.50	13.50	14*1500
9P	24.0	11.50	14.85	14*1500
10P	32.0	14.20	16.10	11*1500
11P	32.0	14.20	17.35	11*1500
12P	32.0	14.20	18.60	11*1500
13P	32.0	14.20	19.85	11*1500
14P	44.0	20.20	21.10	8*1500

NO.	NAME	SPEC.	Q'TY
①	PRODUCT	GH1.25 SMT 90°WF系列	参照上表(特殊除外)
②	卷盘/载带	--	1SET
③	透明真空袋	550×500×0.10mm	1PCS/Reel
④	干燥剂	--	1PCS/Reel
⑤	三角纸板	410×80×80mm	4PCS
⑥	纸箱	400×400×420mm	1PCS
⑦	标签	--	2PCS



MARK

1

2

3

4

5

6

7

8

9

TOLERANCE

X.X ±0.30
X.XX ±0.20
X.XXX ±0.10
Angle ±2°

TITLE:

GH1.25 SMT 90° WF
卷装包装规范

DRAWN: Arvin 2020.03.05

CHECKED:

APPROVED:

UNIT: mm

SCALE: N/A

SHEET: 1/1

PROJECTION

KONNRA 东莞市康瑞电子有限公司
DongGuan Konnra Electronics Co., Ltd.

PART NO.: C1259RS1**09*010*RA

REV.: A1 DRAWING NO.: 1259WRS101-A-P