

RoHS
COMPLIANT

Step 1: Place Housing into PE bag and seal PE bag. Label.

将 Housing放入PE袋内, 并将PE袋封好, 贴上标签.

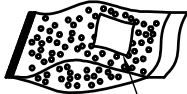
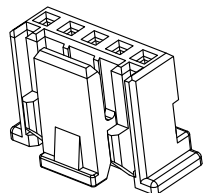

Label

Step 2: Put PE bag packed products in cartons,

Packing detail see the table right

将装好产品的PE袋放入纸箱内, 详细包装见右表

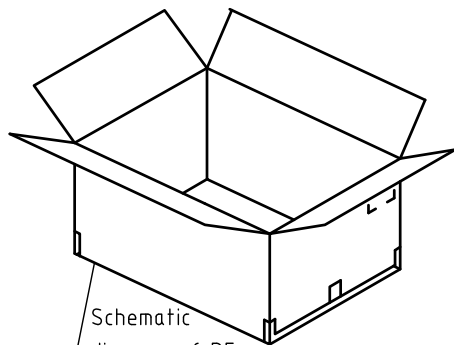

Schematic diagram of PE bag placement

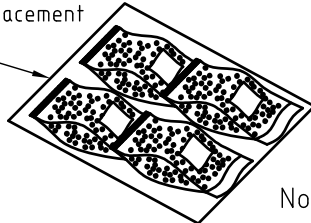

Step 3: Put PE bag packed products in cartons,

Packing detail see the table right

将装好产品的PE袋放入纸箱内, 详细包装见右表

Adhesive Tape

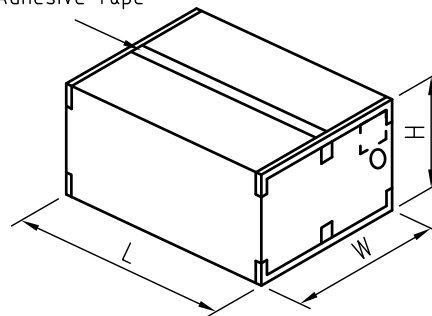

Circuits	PCS/Bag
2	1000
3	1000
4	1000
5	1000
6	1000
7	1000
8	1000
9	1000
10	1000
11	1000
12	1000
13	1000
14	1000
15	1000

Note注解:

1. There shall be no dirt such as deformation phenomenon, Mantissa box fillers must be used
每箱不可有脏污, 变形现象, 尾数箱必须用填充物
2. Confirm whether the inner and outer labels are missing and the content must be consistent with the actual product
确认内外标签有无漏失, 内容与实物必须一致
3. Packing quantity per carton depends on order and delivery quantity
每箱包装数量依订单及交货数量而定

	SPEC.	Remark
Carton 1	L460mm×W460mm×H510mm	Use the appropriate carton size according to the actual order quantity 根据实际订单数量使用合适的纸箱尺寸
Carton 2	L500mm×W500mm×H305mm	
Carton 3	L580mm×W580mm×H320mm	



MARK

1

2

3

4

5

6

7

8

9

TOLERANCE

X.X ±0.30

X.XX ±0.20

X.XXX ±0.10

Angle ±2°

TITLE:

PA2.0 Housing

Packing

DRAWN:

Arwin 2020.03.05

CHECKED:

APPROVED:

KONNRA 东莞市康瑞电子有限公司

DongGuan Konnra Electronics Co.,Ltd.

PART NO.: H2014****01B

REV.: A1

DRAWING NO.: 2014H101-B-P

UNIT:mm

SCALE:N/A

SHEET: 1/1

PROJECTION



RoHS
COMPLIANT

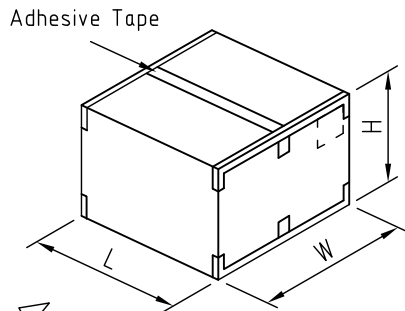
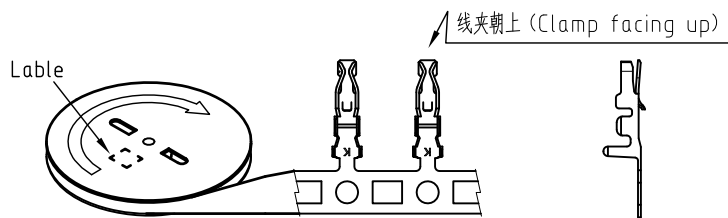

Package way

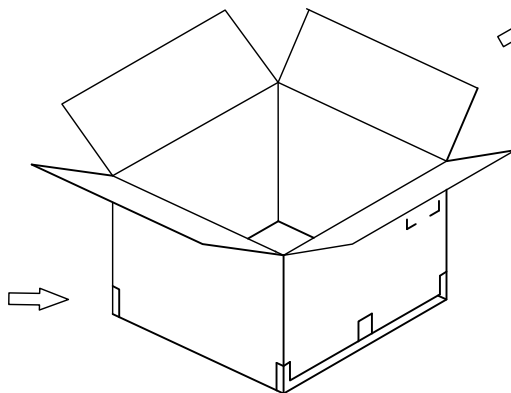
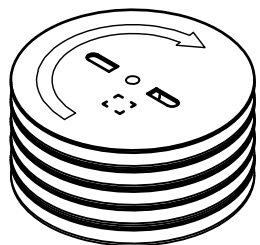

Note注解:

1. There shall be no dirt such as deformation phenomenon, Mantissa box fillers must be used
每箱不可有脏污，变形现象，尾数箱必须用填充物
2. Confirm whether the inner and outer labels are missing and the content must be consistent with the actual product
确认内外标签有无漏失，内容与实物必须一致
3. Quantity(数量): 10K PCS/REEL (10K PCS/盘)
Packing quantity per carton depends on order and delivery quantity
每箱包装数量依订单及交货数量而定

	SPEC.	Remark
Carton 1	L460mm×W460mm×H510mm	Use the appropriate carton size according to the actual order quantity 根据实际订单数量使用合适的纸箱尺寸
Carton 2	L500mm×W500mm×H305mm	
Carton 3	L580mm×W580mm×H320mm	



MARK

1

2

3

4

5

6

7

8

9

TOLERANCE
X.X ±0.30
X.XX ±0.20
X.XXX ±0.10
Angle ±2°

TITLE:
PHD/PA2.0 Terminal
Packing

UNIT:mm SCALE:N/A

DRAWN: *Arwin 2020.03.05*
CHECKED:
APPROVED:

SHEET:1/1 PROJECTION

KONNRA 东莞市康瑞电子有限公司
DongGuan Konnra Electronics Co.,Ltd.
PART NO.:T20050**0101A

REV.:A1 DRAWING NO.:2005T01-A-P

RoHS
COMPLIANT

Step 1: Place Housing into PE bag and seal PE bag. Label.

将 Housing放入PE袋内, 并将PE袋封好, 贴上标签.

Step 3: Put PE bag packed products in cartons,

Packing detail see the table right

将装好产品的PE袋放入纸箱内, 详细包装见右表

PA2.0 DIP 90° / PA2.0 DIP 180°

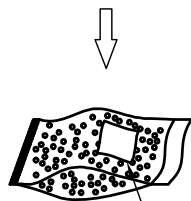
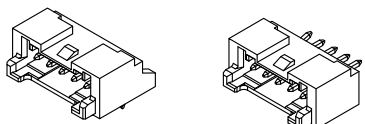

Label

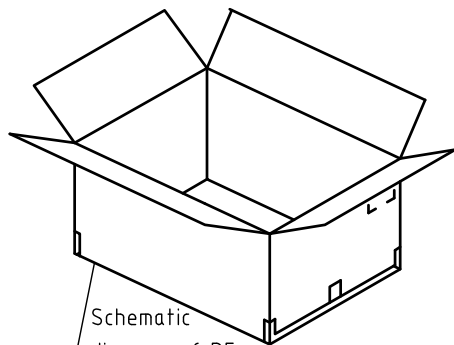

Schematic diagram of PE bag placement

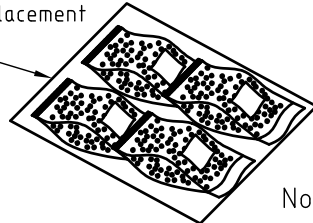

Adhesive Tape

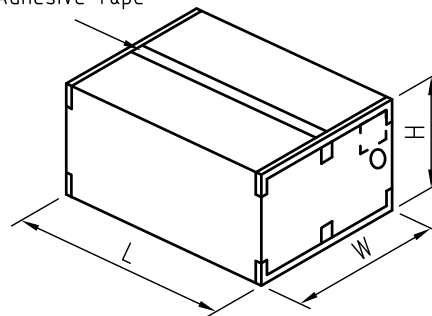

Step 2: Put PE bag packed products in cartons,

Packing detail see the table right

将装好产品的PE袋放入纸箱内, 详细包装见右表

Circuits	PCS/Bag
2	1000
3	1000
4	1000
5	1000
6	1000
7	1000
8	1000
9	1000
10	1000
11	1000
12	1000
13	1000
14	1000
15	1000
16	1000

Note注解:

1. There shall be no dirt such as deformation phenomenon, Mantissa box fillers must be used
每箱不可有脏污, 变形现象, 尾数箱必须用填充物
2. Confirm whether the inner and outer labels are missing and the content must be consistent with the actual product
确认内外标签有无漏失, 内容与实物必须一致
3. Packing quantity per carton depends on order and delivery quantity
每箱包装数量依订单及交货数量而定

	SPEC.	Remark
Carton 1	L460mm×W460mm×H510mm	Use the appropriate carton size according to the actual order quantity 根据实际订单数量使用合适的纸箱尺寸
Carton 2	L500mm×W500mm×H305mm	
Carton 3	L580mm×W580mm×H320mm	



MARK

1

2

3

4

5

6

7

8

9

TOLERANCE

X.X ±0.30

X.XX ±0.20

X.XXX ±0.10

Angle ±2°

TITLE:

PA2.0 DIP WF

Series Packing

UNIT:mm

SCALE:N/A

DRAWN:

Arwin 2020.03.05

CHECKED:

APPROVED:

SHEET:1/1

PROJECTION

KONNRA 东莞市康瑞电子有限公司

DongGuan Konnra Electronics Co.,Ltd.

PART NO.:C2014*****01PA

REV.:A1

DRAWING NO.:2014WND101-A-P

RoHS
COMPLIANT

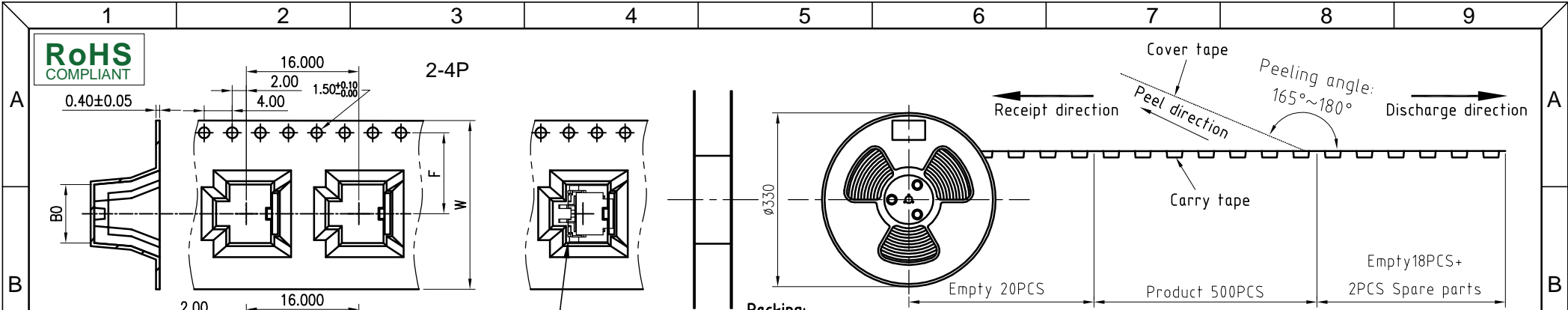

Packing:

The product is loaded into the carrier tape as required (see "Product Tape and Reel Packaging Table"), to be tested with the stripping force (stripping angle: 165~180°; peel speed: 300 ± 10 mm / min); Peel force 0.1N ~ 1.3N;

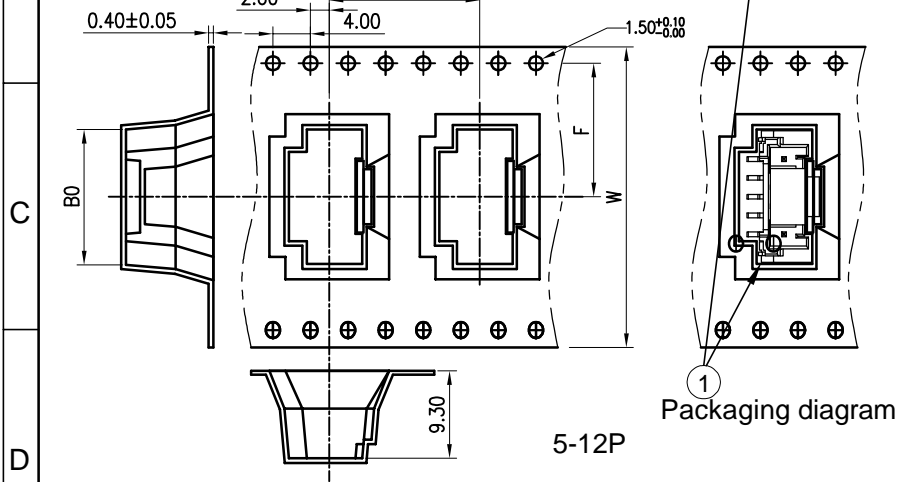

① Packaging diagram

NO.	NAME	SPEC.	Q'TY
①	Product	PA2.0 SMT 180° WF 系列	500 PCS
②	Reel/Tape	--	1SET
③	Vacuum bag	500×440×0.10mm	1PCS/Reel
④	Desiccant	--	1PCS/Reel
⑤	cardboard	410×80×80mm	2PCS
⑥	carton	350×350×420mm	1PCS
⑦	Label	--	2PCS

Pin数	W±0.3	F±0.2	B0±0.2	q'ty/BOX
2P~4P	24	11.5	8.30~12.30	14*500
5P~8P	32	14.2	14.30~20.30	11*500
9P~12P	44	20.2	22.30~28.30	8*500

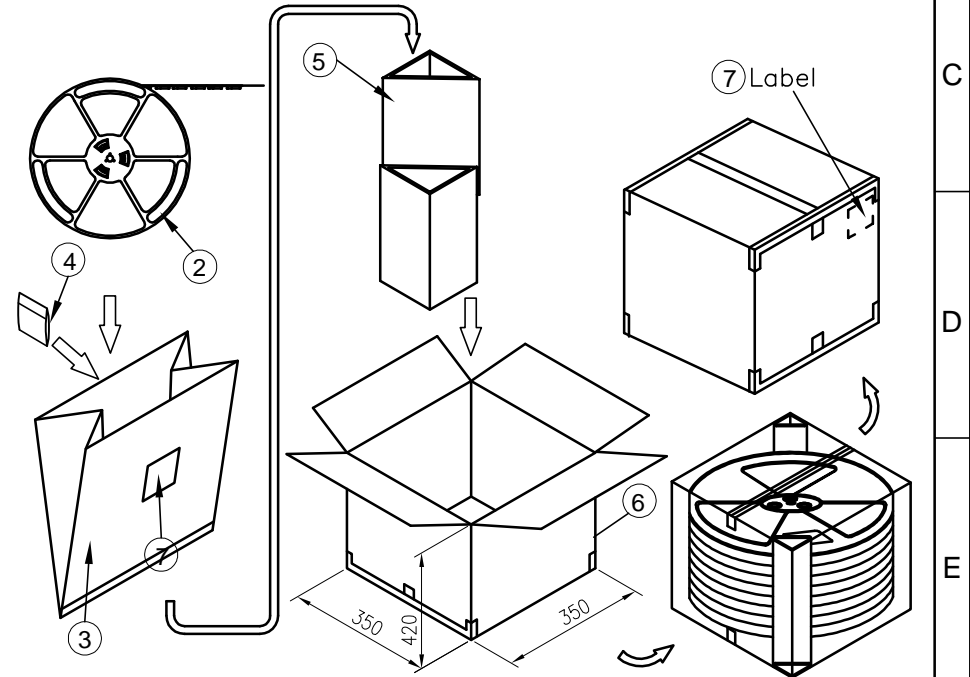

MARK	REVISION DESCRIPTION	SIGNATURE	DATE	TOLERANCE	TITLE:	DRAWN:	KONNRA 东莞市康瑞电子有限公司		
△4				X.X ±0.30	PA2.0 SMT 180°	Arvin 2021.07.22	DongGuan Konnra Electronics Co., Ltd.		
△3				X.XX ±0.20	Wafer 系列Package	CHECKED:			
△2				X.XXX ±0.10	Specification	APPROVED:	PART NO.: C2014VS***11M101RA		
				Angle ±2°	UNIT: mm SCALE: N/A	SHEET: 1/1 PROJECTION	REV.: A1	DRAWING NO.: 2014WS101-A-P	
1	2	3	4	5	6	7	8	9	

